

Dist. Cancelling P-P Amp - Power  
Pete Millett 2009 www.pmillett.com

TITLE: DCP

Document Number:

REV:

Date: 9/05/2009 02:15:12p

Sheet: 1/3

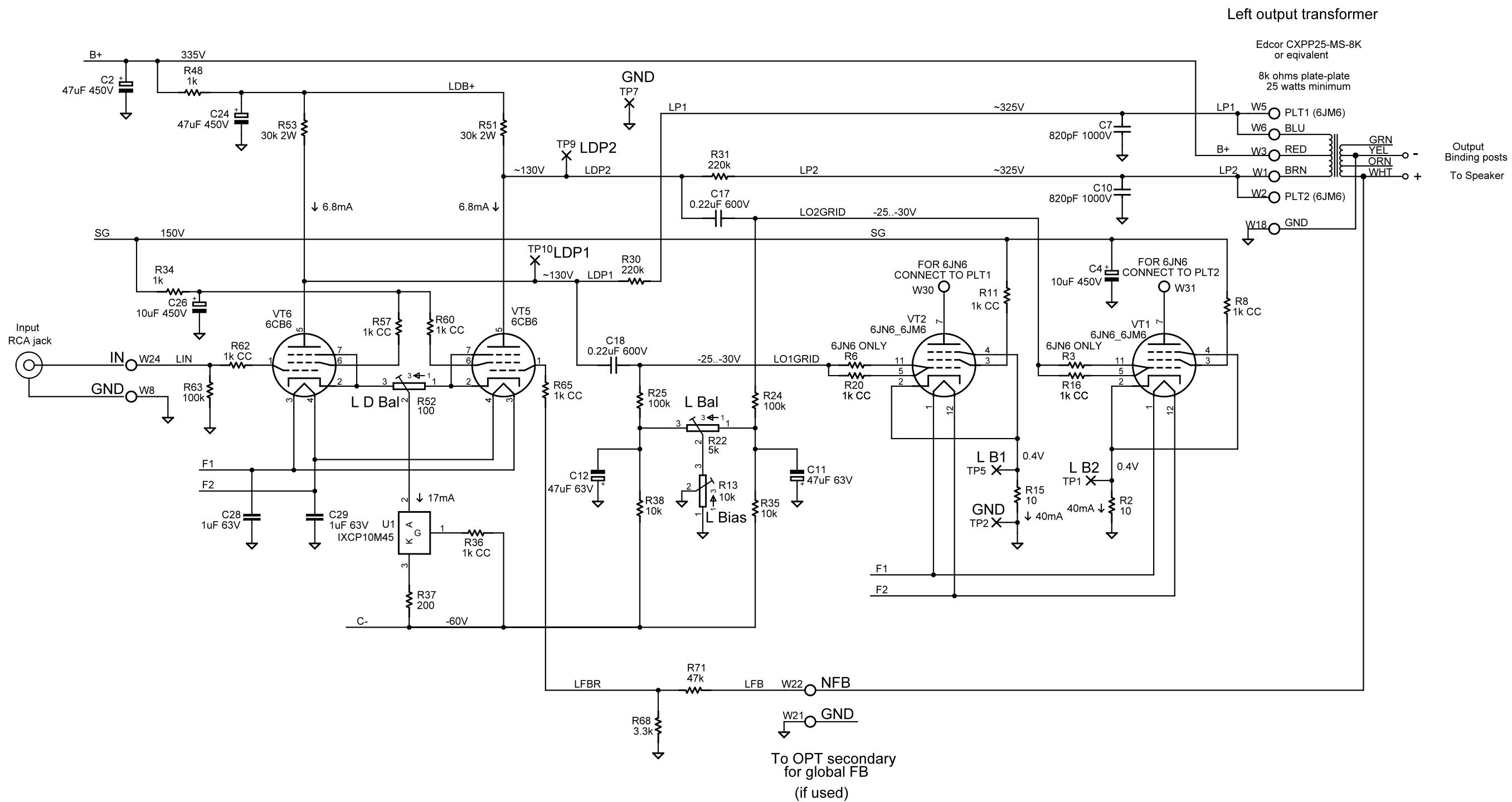

Dist. Cancelling P-P Amp - Left  
Pete Millett 2009 www.pmillett.com

TITLE: DCPP

Document Number:

REV:

Date: 9/05/2009 02:15:12p

Sheet: 2/3

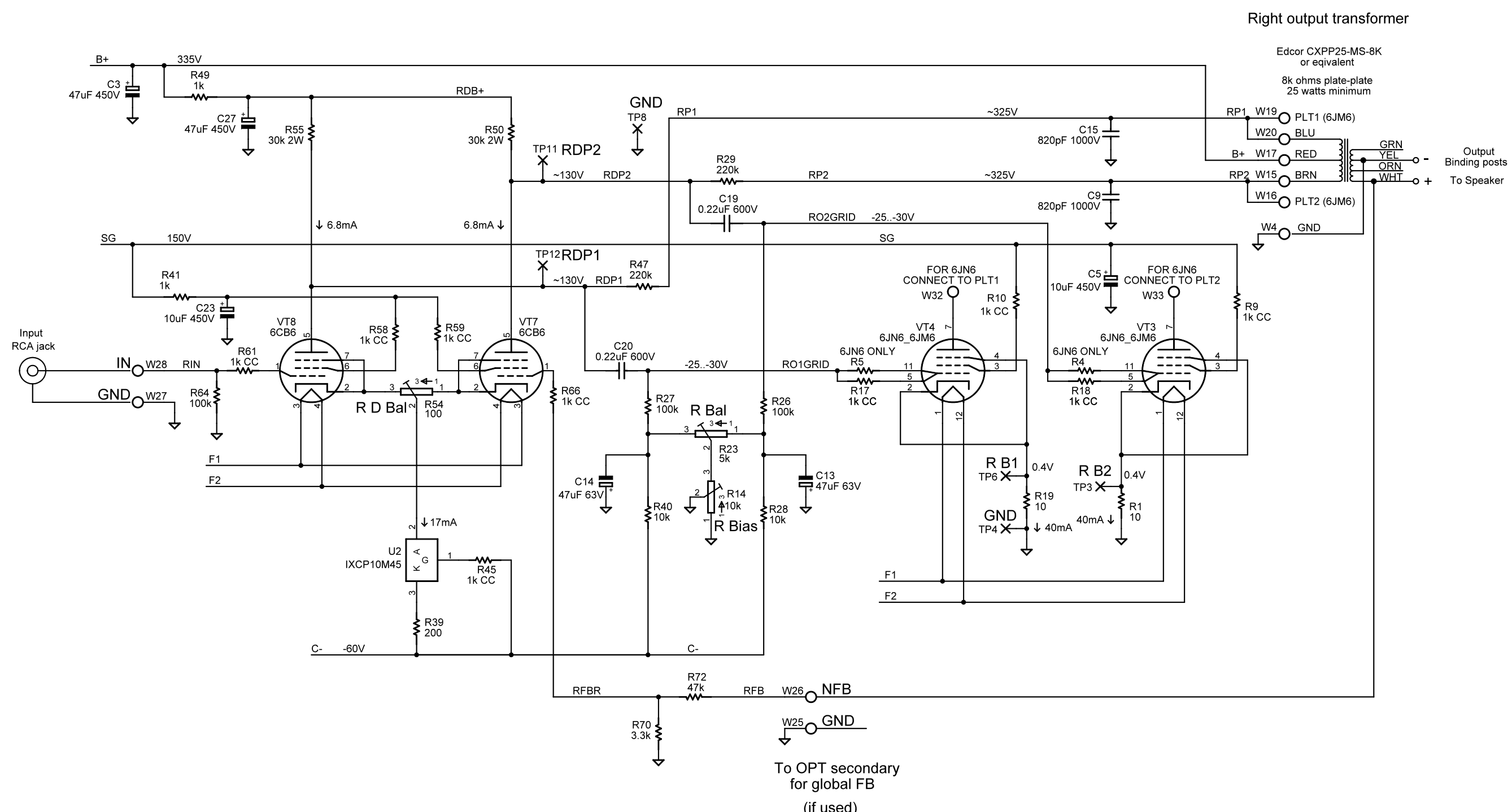

Right output transformer

Ecor CXPP25-MS-8K  
or equivalent  
8k ohms plate-plate  
25 watts minimum

Output  
Binding posts  
To Speaker

Dist. Cancelling P-P Amp - Right  
Pete Millett 2009 www.pmillett.com

TITLE: DCPP	
Document Number:	REV:
Date: 9/05/2009 02:15:12p	Sheet: 3/3